

 soundmaster®
highline



DEUTSCH
ENGLISH
FRANÇAIS
NEDERLANDS
ESPAÑOL
PORTUGUÊS

USB 

SD CARD

MP3
PLAYBACK

ENCODE
Aufnahme von Platte
auf USB-Stick / SD-Karte

PL530USB

ENVIRONMENTAL PROTECTION



Do not dispose of this product with the normal household waste at the end of its life cycle. Return it to a collection point for the recycling of electrical and electronic devices. This is indicated by the symbol on the product, user manual or packaging.

The materials are reusable according to their markings. By reusing, recycling or other forms of utilization of old devices you make an important contribution to the protection of our environment.

Please contact your local authorities for details about collection points.

CLASS 1 LASER PRODUCT
KLASSE 1 LASER PRODUKT
LUOKAN 1 LASER LAITE
KLASS 1 LASER APPARAT
PRODUCTO LASER CLASE 1

CAUTION - INVISIBLE LASER RADIATION WHEN OPENING THE COVER OR PRESSING THE SAFETY INTERLOCK. AVOID EXPOSURE TO THE LASER BEAM.

	WARNING Risk of electric shock Do not open!	
Caution: To reduce the risk of electric shock, do not remove the cover (or back). There are no user serviceable parts inside. Refer servicing to qualified service personnel.		



This symbol indicates the presence of dangerous voltage inside the enclosure, sufficient enough to cause electric shock.



This symbol indicates the presence of important operating and maintenance instructions for the device.

Safety, Environmental and Setup Instructions

- Use the device in dry indoor environments only.
- Protect the device from humidity.
- Do not open the device. **RISK OF ELECTRIC SHOCK!** Refer opening and servicing to qualified personnel.
- Connect this device to a properly installed and earthed wall outlet only. Make sure the mains voltage corresponds with the specifications on the rating plate.
- Make sure the mains cable stays dry during operation. Do not pinch or damage the mains cable in any way.
- A damaged mains cable or plug must immediately be replaced by an authorized service center.
- In case of lightning, immediately disconnect the device from the mains supply.
- Children should be supervised by parents when using the device.
- Clean the device with a dry cloth only.
Do NOT use CLEANING AGENTS or ABRASIVE CLOTHS!
- Do not expose the device to direct sunlight or other heat sources.
- Install the device at a location with sufficient ventilation in order to prevent heat accumulation.
- Do not cover the ventilation openings!
- Install the device at a safe and vibration-free location.
- Install the device as far away as possible from computers and microwave units; otherwise radio reception may be disturbed.
- Do not open or repair the enclosure. It is not safe to do so and will void your warranty. Repairs only by authorized service/ customer center.
- The device is equipped with a "Class 1 Laser". Avoid exposure to the laser beam as this could cause eye injuries.
- Only use mercury and cadmium-free batteries.
- Used batteries are hazardous waste and NOT to be disposed of with the household waste!!! Return the batteries to your dealer or to collection points in your community.
- Keep batteries away from children. Children might swallow batteries. Contact a physician immediately if a battery was swallowed.
- Check your batteries regularly to avoid battery leakage.



Used batteries are hazardous waste and NOT to be disposed of with the household waste! As a consumer you are **legally obligated** to return **all batteries** for environmentally responsible recycling – no matter whether or not the batteries contain harmful substances*).

Return batteries free of charge to public collection points in your community or to shops selling batteries of the respective kind.

Only return fully discharged batteries.

*) marked Cd = cadmium, Hg = mercury, Pb = lead

LOCATION OF CONTROLS

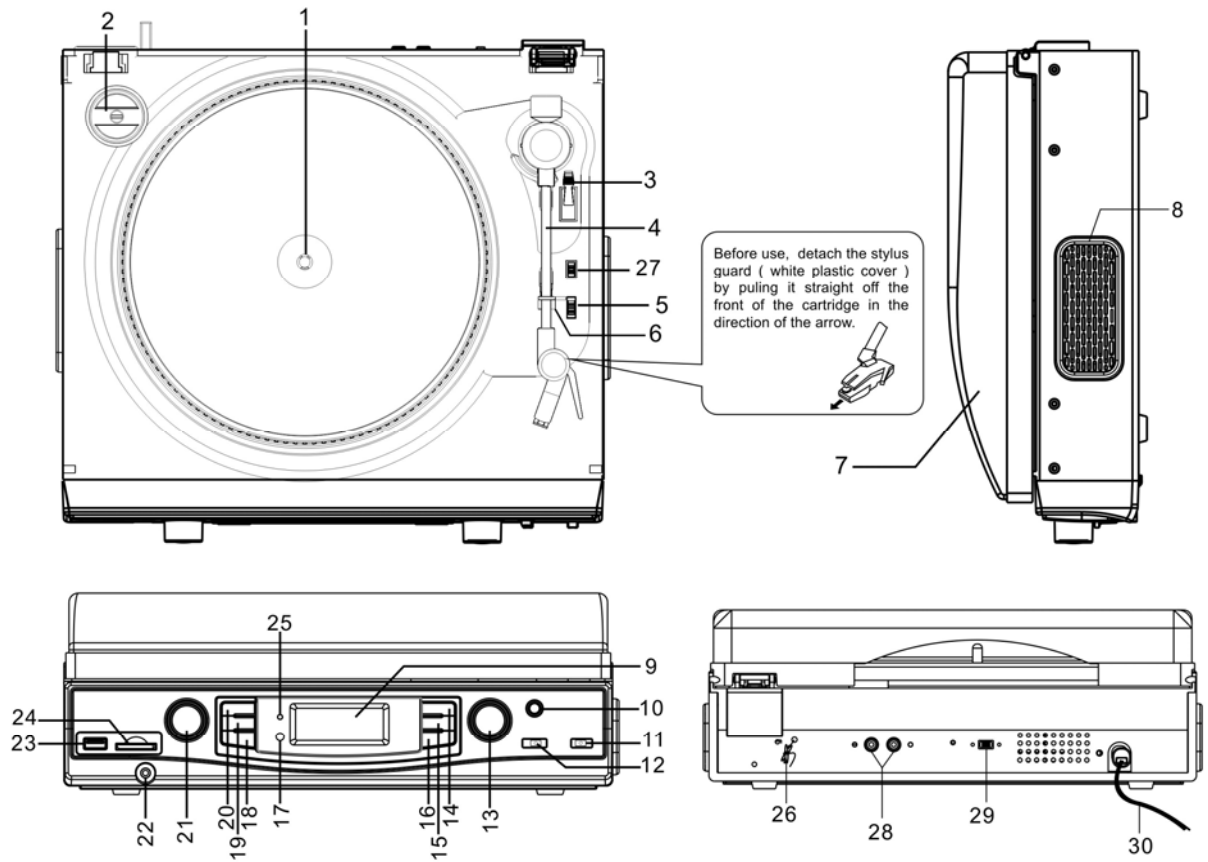

- | | |
|--|---|
| <ul style="list-style-type: none"> 1. Turntable 2. 45 RPM Adapter 3. Cue-lever (use this lever to lift the tone arm) 4. Tone Arm 5. Speed Selector 6. Tone Arm Holder 7. Dust Cover 8. Speaker 9. Display 10. Bass Boost Button 11. Function Selector 12. Band Selector 13. Tuning Control 14. Skip + Button 15. Skip – Button 16. Mode Button Program, Repeat 1, Repeat Album, Repeat All, Intro, Random) | <ul style="list-style-type: none"> 17. IR Sensor 18. Record Button 19. Stop/USB/Card Button 20. Play / Pause Button 21. Volume Control 22. Headphone Jack 23. USB Port 24. SD/MMC Card Slot 25. Power Indicator 26. FM Antenna 27. Auto Stop (ON/OFF) Selector 28. Line-Out Output Socket for connect to amplifier 29. Internal Speaker (ON / OFF) Selector 30. AC Power Cord |
|--|---|

POWER SOURCE

This Unit is designed to only operate on normal 230V~ 50Hz household power. Do not attempt to operate the System using any other power source. You could cause damage to the unit and void your warranty.

The remote control unit operates on 1 CR2025 Lithium battery (Included).

AC OPERATION

1. Plug the AC POWER CORD into a 230V AC ~ 50Hz outlet.
2. Turn the System on by sliding the Function Selector (11) to either "TUNER", "USB/SD" or "PHONO". The LCD backlight will turn on.

Mains plug should be regularly checked for any damage. If it is damaged do not operate the unit, seek advice from a qualified service technician. Do not attempt to operate the unit on any other power source as this could cause damage to the unit and void your warranty.

Remarks:

If there is a malfunction due to electrostatic discharge (ESD), reset the unit by unplugging the AC CORD from the outlet, wait 30 seconds and then plug the AC CORD in again to reset to normal operation.

RADIO OPERATION

1. Slide the FUNCTION Selector (11) to the "TUNER" position.
2. Slide the BAND Selector (12) to either AM, FM or FM ST (FM Stereo Mode).
3. Rotate the TUNING CONTROL (13) until you reach the radio station you wish to listen to. The radio station frequency shows on the LCD DISPLAY.
4. Adjust the sound level by rotating the VOLUME CONTROL (21).
5. To turn off the radio, Slide the FUNCTION Selector (11) to the "OFF" position. The LCD DISPLAY will go "off".

FM stereo RECEPTION

1. With the BAND Selector (12) in the "FM ST" position, the FM Stereo Indicator "" will light up when listening to a strong station that is broadcasting in "Stereo".
2. Slide the BAND Selector (12) to the FM position if the FM stereo reception is weak. The reception may improve, but the sound is now monaural (MONO).

TIPS FOR BEST RECEPTION

- AM – The AM antenna is located inside the cabinet of the main unit. If AM reception is weak, change the position of cabinet until the internal antenna picks up the strongest AM signal.
- FM – During FM reception, always keep the FM Wire Antenna fully extended. If FM reception is weak try repositioning the FM Wire Antenna until you find the strongest FM signal

PLAYING PHONO RECORDS

1. Raise the Turntable Dust Cover.
2. Remove the stylus protector and release the Tone Arm Clamp (6).
3. Slide the Function Selector (11) to "PHONO".
4. Place a record on the turntable, over the center spindle.
5. Set the Speed Selector Switch to 33, 45 or 78 rpm according to the record you are playing. Place the included 45 RPM adaptor (2) over the center spindle when playing 45 rpm records.
6. Move the Tone Arm to the beginning of the record or to the beginning of a particular track. Gently lower the Tone Arm onto the record to start playing. Adjust the Volume if needed. The Turntable will stop automatically when the record finishes.
7. To stop the record before it ends, lift the Tone Arm (4) using the Cue-lever (3) and return it carefully onto the Tone Arm Clamp (6).
8. Replace the stylus protector on the stylus when not in use.



NOTE:

- i. Do not stop or turn the platter manually.
- ii. Moving or jarring the turntable without securing the Tone arm clamp could result in damage to the Tone arm.

AUTO-STOP SWITCH OPERATION

The Auto-Stop area on some records may extend beyond the preset setting. As a result the turntable could possibly stop before the last track finishes. If you experience this during playback, set the AUTO-STOP Switch (27) located on the back of the unit to the "OFF" position. The turntable will now run to the end of the record, but will no longer stop automatically. To stop the turntable you will need to either set the Function Selector (11) to the OFF position or return the AUTO-STOP Switch (27) to the "ON" position. After the record stops, lift and return the Tone Arm (4) carefully back onto the Tone Arm Clamp (6).

IMPORTANT:

Moving or jarring the Turntable without securing the Tone Arm Clamp (6) could result in damage to the Tone Arm (3).

USING HEADPHONES (NOT INCLUDED)

This System accepts stereo headphones with a 3.5mm plug and an impedance of 8 ohms or greater. Inserting the plug of your headphones into the Headphone jack (22) will enable you to listen privately. When using headphones, the speakers will be disconnected automatically.

READ THIS IMPORTANT INFORMATION BEFORE USING YOUR HEADPHONES

1. Avoid extended play at very high volume as it may impair your hearing.
2. If you experience ringing in your ears, reduce the volume or shut off your unit.
3. Keep the volume at a reasonable level even if your headset is an open-air type designed to allow you to hear outside sounds. Please note that excessively high volume may still block outside sounds.

NOTE:

We recommend that you reduce the volume control to a lower level before putting on the headphones. After putting on the headphones, gradually increase the volume to a comfortable listening level.

ENCODING RECORDS(PHONO) TO MP3

You can convert you favorite records into MP3 files and store then on a USB Flash Drive or SD/MMC Memory Card via the USB port (23) or SD/MMC slot (24) located on the front panel.

1. Insert a USB flash drive into the USB PORT (23) or an SD/MMC Memory Card into the SD/MMC Slot (24) located on the front panel.
2. Press the RECORD Button (18), "REC" and "USB" will begin to flash in the display, If a USB Flash Drive is inserted. If an SD/MMC Card is inserted then "REC" and "CARD" will flash in the display. If both USB and SD/MMC card are inserted, then Icon "SEL" will also appear and flash in the Display.
3. You can use the SKIP + Button (14) or the SKIP - Button (15) to select what media you want to record to.
4. Select the track to be encoded and start playing the record.
5. Press the Record button to start sync encoding. The following will be displayed depending on what media you are using to store the music.



Encoding to USB



Encoding to Card

6. To stop encoding press the STOP/USB/SD Button (19).

Note: To ensure the encoding is successful, remove the USB or Card a few seconds after pressing the STOP Button.

- To start recording again, press the RECORD Button (18) again and follow step #2 above.

PLEASE NOTE : If you want to encode an entire side of a record and have separate MP3 files for each track, you must manually press the STOP/USB/SD Button (19) at the end of each track and then press the RECORD Button (18) again to start recording the next track. If you do not manually Stop and Start the recording process after each track, you will end up with one large MP3 file that will have all the songs from the side of the record playing one after the other.



USB / CARD OPERATION

The following tasks can be accomplished by either using the controls on the REMOTE Control or those which have similar function markings on the unit.



- Select the USB / CARD function mode by setting the Function selector (11) to "USB/CARD". The Display will show "USB NO" when the USB port is empty.
- Insert either a USB flash drive into the USB PORT (23) or an SD/MMC Memory Card into the SD/MMC Slot (24). Press and hold the STOP/USB/CARD Button (3) for 2 seconds to switch between USB and CARD modes if necessary.
- The total number of tracks on the USB or SD/MMC card will be displayed and playback will automatically start from the first track depending which mode you have chosen (USB or CARD).



- NOTE: i. MP3 file formats are supported.
ii. Not all brands of USB flash drives are supported.

- To interrupt playback, press the  button (20). The track being played will flash.
- To resume playback, press the  Button (20) again.
- To stop playback, briefly press the STOP button (19).

TRACK SKIP

To select a particular track, in Stop mode or during playback, press the  or  buttons (4, 5){Remote} repeatedly until the desired track number appears on the display. The selected track will start playback automatically.

FOLDER SKIP

To select a particular folder, in Stop mode or during playback, press the FOLDER UP /DOWN Button (10,11){Remote}, until the track number (first track number) of the Album appears in the Display. Playback of the first track of the selected folder will start automatically.

REPEAT 1/ FOLDER/ ALL PLAYBACK

1. During playback, if you want to repeat the same track, simply press the MODE (9) Button once '  ' appears in the Display.



2. The track will be repeated and stop until the STOP Button (3) is pressed.
3. To repeat a Folder, press the MODE button twice. "FOLDER" will light up.

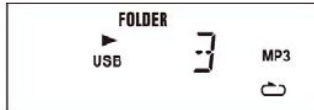

4. The selected Folder will be repeated and stop until the STOP Button is pressed.
5. To repeat all the tracks, press the MODE Button 3 times and the Repeat All Indicator "  " will light up.



6. All the tracks of the storing device will be repeated until the STOP Button is pressed.
7. To cancel repeat play, press the MODE button repeatedly until all the repeat indicator disappear in the Display.

INTRO PLAY

This function enables the first 10 seconds of each track to be played.

1. During playback press MODE button four times, the Intro Indicator "INTRO" will light up.



2. Press the  button once to start playback from the next track.
3. To cancel intro play, press the MODE Button (9) twice.

RANDOM PLAY

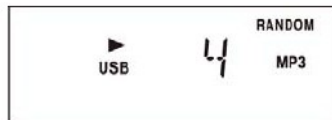

1. During playback press the MODE button five times, the Random Indicator "RADDOM" will light up.



2. Press the  button once. A track is selected at random and playback starts.
3. To cancel random play, press the MODE Button again. The Random Indicator 'RANDOM' disappears in the Display.

PROGRAMMED PLAY

Programmed play can only be achieved in Stop mode.

1. In stop mode, briefly press the MODE button (16) on the unit. Program Channel No. 'P1' will briefly appear. 'P' will then disappear leaving the Program Indicator, 'PROG' and '1' flash in the Display to prompt for input.
2. Press the  or  buttons (4, 5) to select your desired track to be stored in the program. For example the first selection is track no.5.

3. Press the MODE button (16) to confirmed when track No.5 flashed in the Display.

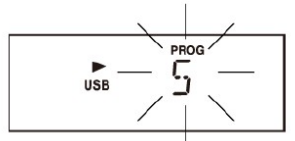

The first program selection is now stored in the program memory.

The Program Channel No. 'P 2' will appear briefly. 'P' will disappear and 2 will revert to 5, i.e. the first selected program and flash together with 'PROG' to prompt for another input.

4. Repeat points 2 and 3 to enter the desired tracks up to max 32 selections.
5. Press the **▶||** button once to start playback in your programmed sequence.
6. To clear the program memory, while playing press the Stop button 2 times or select TUNER, PHONO function or turn the System off.

COPYING FILES BETWEEN USB AND CARD

The files stored on your USB flash drive or on the SD/MMC card can be copied to each other. Please follow the instructions below to copy the files between the USB port and the Card slot.

1. Insert your USB flash drive into the USB PORT (23) and the SD/MMC Memory Card into the SD/MMC Slot (24).
2. Select the USB / CARD function mode by setting the Function selector (11) to "USB/CARD". The total number of tracks on the USB will be displayed and playback will automatically start from the first track.
3. Press the STOP/USB/SD Button once to stop the playback. Copy of the USB files to the Card is now ready to proceed any time. If you want to copy the files from the Card to the USB, you need to enter the Card playback Stop mode first then proceed to Step 4 below for copying.



USB Playback Stop Mode



Card Playback Stop Mode

4. To start recording briefly press the RECORD Button once.



Copying USB Files to Card



Copying Card Files to USB

5. To stop copying, briefly press the STOP Button once.

DELETING FILES

1. With the USB or Card in the playback stop mode, press **▶▶** or **◀◀** buttons to select the track to delete, for example track 5 is selected.
2. When the desired track appears in the Display press and hold the RECORD Button(17) to confirm. 'DEL' will flash few times and then disappear. The chosen track, '005', will appear and blink in the Display to prompt for confirmation. In case you want to cancel the delete function just briefly press the STOP Button.



- To confirm, briefly press the RECORD button once. 'DEL' will appear steadily in the Display for few seconds and then the Display will resume to USB/Card playback stop mode with the total track number deducted by 1.



Original 38 Files



After Deleting Track 5

- Repeat 1-3 above to delete more tracks as desired.

Bass boost OPERATION

To enhance the low frequency sound, press the BASS BOOST BUTTON (13) once (button in) to activate. Press the BASS BOOST Button (13) again (button out) to turn the Bass Boost off.

Note: Please refer to the ON/OFF graphic on the Front Panel for correct operation of the Bass Boost function

REMOTE CONTROL UNIT

- PLAY/PAUSE BUTTON
- RECORD BUTTON
- STOP/USB/SD BUTTON
- SKIP- BUTTON
- SKIP+ BUTTON
- DISPLAY BUTTON
- TS BUTTON (TRACK separation for split next song)
- PROG BUTTON
- MODE BUTTON (Repeat 1, Repeat Album, Repeat All, Intro, Random)
- FOLDER UP BUTTON
- FOLDER DOWN BUTTON
- DELETE BUTTON

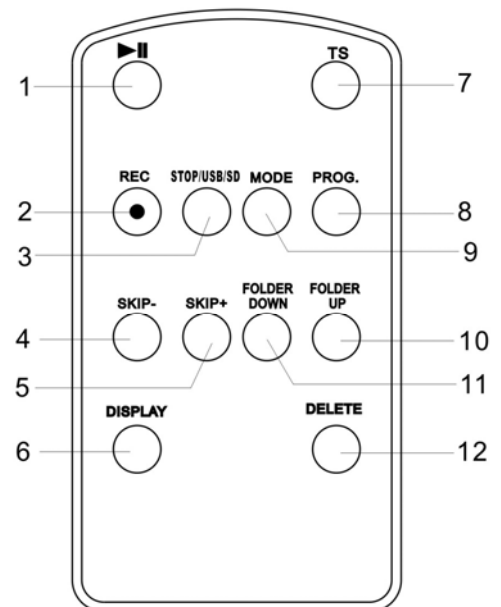

TS BUTTON (Track separation, press it for split next song)

IT IS HELPFUL WHEN RECORDING A VINYL TO USB OR SD, MMC. PRESS ONCE THE TS BUTTON WHEN FINISHED A SONG, IT GENERATE A NEW FILE FOR ANOTHER SONG, BUT IT TAKES AROUND 6 – 10 SECONDS TO READ THE USB OR SD/MMC. IT SHOULD TAKE NOT THAT MAY NOT BE RECORD COMPLETED SONG.

ACTIVATING THE REMOTE CONTROL

Remove the plastic insulator tag sticking out of the Battery Compartment of the Remote Control by pulling on it. Once the tag is removed, the Remote Control will be ready for use.

BATTERY CARE

- i. If the unit is not to be used for an extended period of time, remove the battery. An old or leaking battery can cause damage to the Remote Control.
- ii. Do not dispose of batteries in fire, batteries may explode or leak.

BATTERY REPLACEMENT

When the battery becomes weak, the operating distance of the Remote Control is greatly reduced and you will need to replace the Lithium battery.

1. Remove the battery compartment from bottom of the Remote Control.
2. Install 1 "CR2025" Lithium battery with the positive side facing up.
3. Replace the battery compartment.

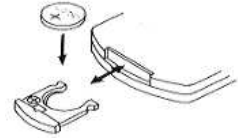

IMPORTANT:

Be sure that the battery is installed correctly. Wrong polarity may damage the Remote Control and void the warranty.

USING THE REMOTE CONTROL CORRECTLY

Note: The Remote Control is only for operating the USB and MMC Card functions.

- Point the Remote Control at the SENSOR (IR) located on the front of the System.
- The functions of the remote buttons are the same as the corresponding controls on the main unit.
- The performance of the infrared SENSOR may be degraded causing unreliable operation if there is a strong ambient light source in the same room.
- The recommended effective distance for remote operation is about 10-15 feet.

The Stylus Replacement

Loose the red part stylus by screw driver and take out as diagram A and B

Replace the new stylus as C and D as diagram

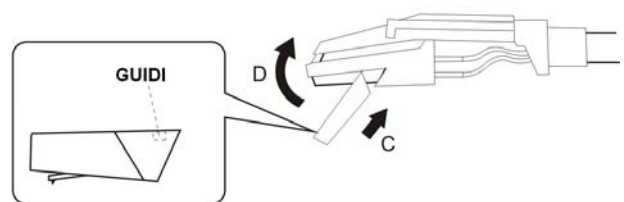
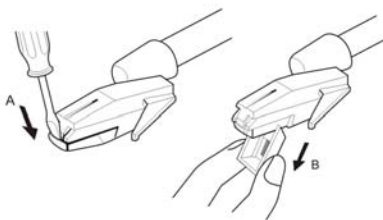

The above diagram illustrates how to replace a new needle (extra needle not supplied).

SPECIFICATIONS

Power Supply:	AC 230V ~ 50Hz
Power consumption:	25W
Radio Frequency Coverage:	FM: 87.5 - 108 MHz AM: 525 – 1620 KHz

Copyright by Woerlein GmbH, 90556 Cadolzburg, www.woerlein.com
Changes of technical specifications without further notice